

**NVACX MATED**

**DESIGNED & DIMENSIONED  
IN MILLIMETERS[INCHES]**

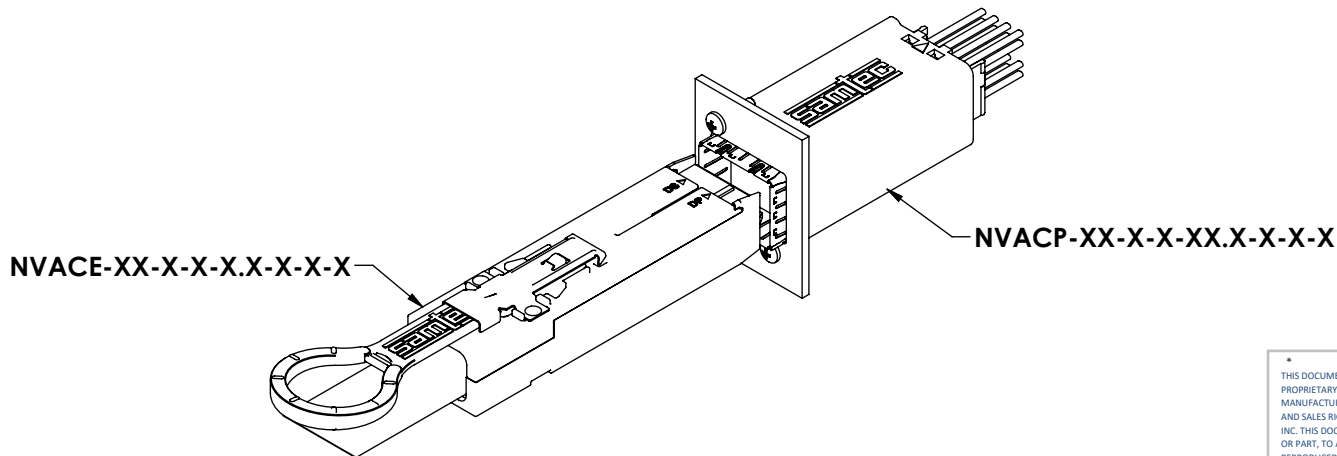
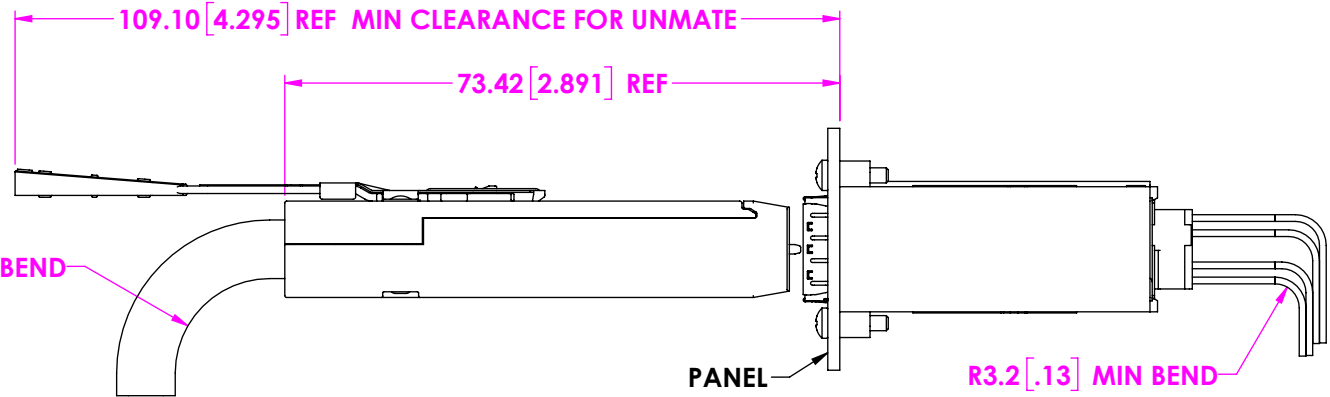
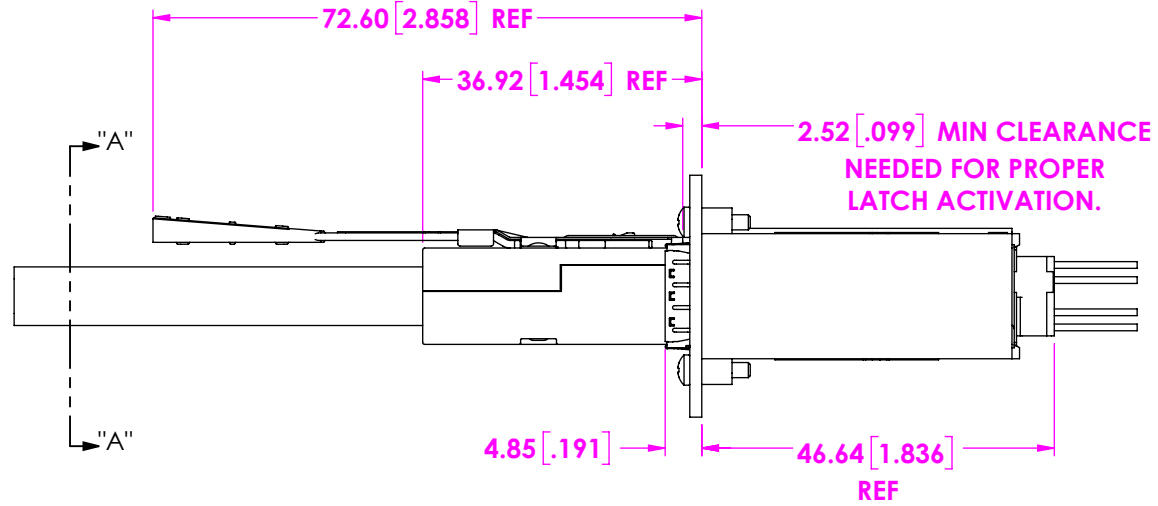
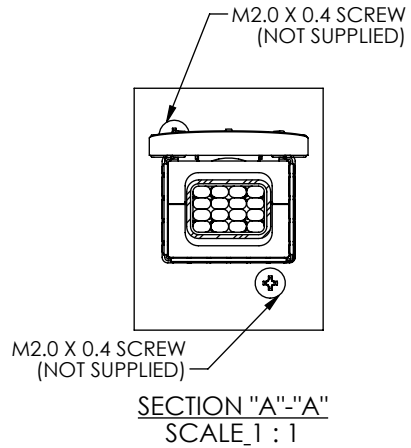

520 PARK EAST BLVD, NEW ALBANY, IN 47150  
PHONE: 812-944-6733 FAX: 812-948-5047  
e-Mail: info@SAMTEC.com code 55322

**PROPRIETARY NOTE**  
THIS DOCUMENT CONTAINS CONFIDENTIAL AND PROPRIETARY INFORMATION AND ALL DESIGN, MANUFACTURING, REPRODUCTION, USE, PATENT RIGHTS AND SALES RIGHTS ARE EXPRESSLY RESERVED BY SAMTEC, INC. THIS DOCUMENT SHALL NOT BE DISCLOSED, IN WHOLE OR PART, TO ANY UNAUTHORIZED PERSON OR ENTITY NOR REPRODUCED, TRANSFERRED OR INCORPORATED IN ANY OTHER PROJECT IN ANY MANNER WITHOUT THE EXPRESS WRITTEN CONSENT OF SAMTEC, INC.

DESCRIPTION: NVACX MATED DOCUMENT  
DWG. NO. NVACX MATED DOCUMENT  
BY: KNOWLDEN 02/25/2022 SHEET 1 OF 4

TOP ALIGNMENT SLOT ON NVACE-XX-X-X-X.X-X-X-X SHOULD BE ON THE SAME SIDE AS THE LATCH HOLES ON NVC-X-XX-XX.

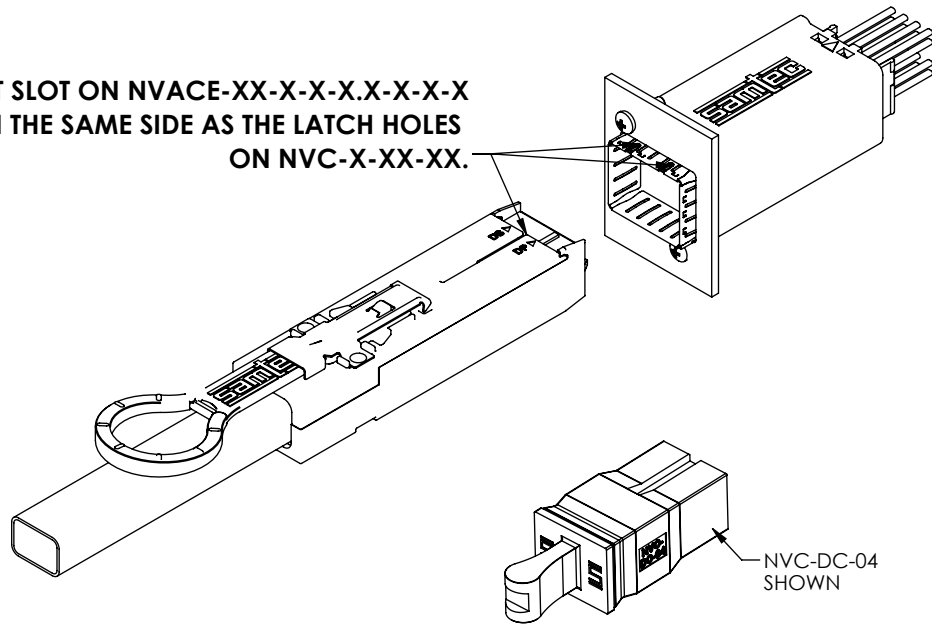

OPTIONAL DUST CAP  
P/N: NVC-DC-XX  
AVAILABLE TO PROTECT OPEN NVACP PORTS

ALIGN SLOTS ON NVACE-XX-X-X-X.X-X-X-X TO GROOVES ON NVACP-XX-X-X-XX.X-X-X-X

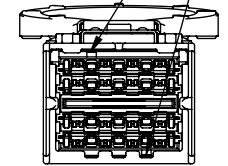
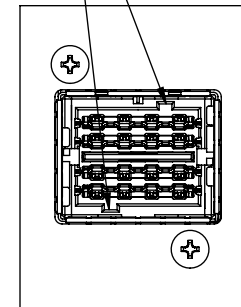

**PROPRIETARY NOTE**  
THIS DOCUMENT CONTAINS CONFIDENTIAL AND PROPRIETARY INFORMATION AND ALL DESIGN, MANUFACTURING, REPRODUCTION, USE, PATENT RIGHTS AND SALES RIGHTS ARE EXPRESSLY RESERVED BY SAMTEC, INC. THIS DOCUMENT SHALL NOT BE DISCLOSED, IN WHOLE OR PART, TO ANY UNAUTHORIZED PERSON OR ENTITY NOR REPRODUCED, TRANSFERRED OR INCORPORATED IN ANY OTHER PROJECT IN ANY MANNER WITHOUT THE EXPRESS WRITTEN CONSENT OF SAMTEC, INC.



520 PARK EAST BLVD, NEW ALBANY, IN 47150  
PHONE: 812-944-6733 FAX: 812-948-5047  
e-Mail info@SAMTEC.com code 55322

DO NOT SCALE DRAWING

SHEET SCALE: 1:2

DESCRIPTION:  
NVACX MATED DOCUMENT

DWG. NO.  
NVACX MATED DOCUMENT

BY:KNOWL DEN 02/25/2022 SHEET 2 OF 4

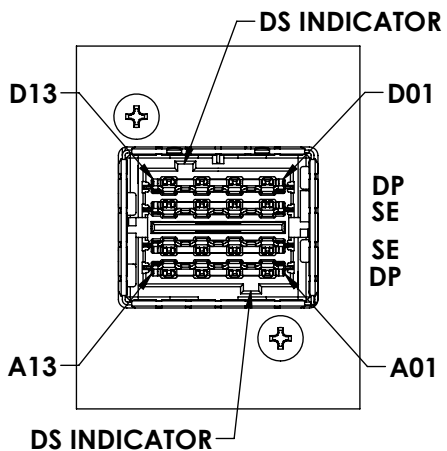
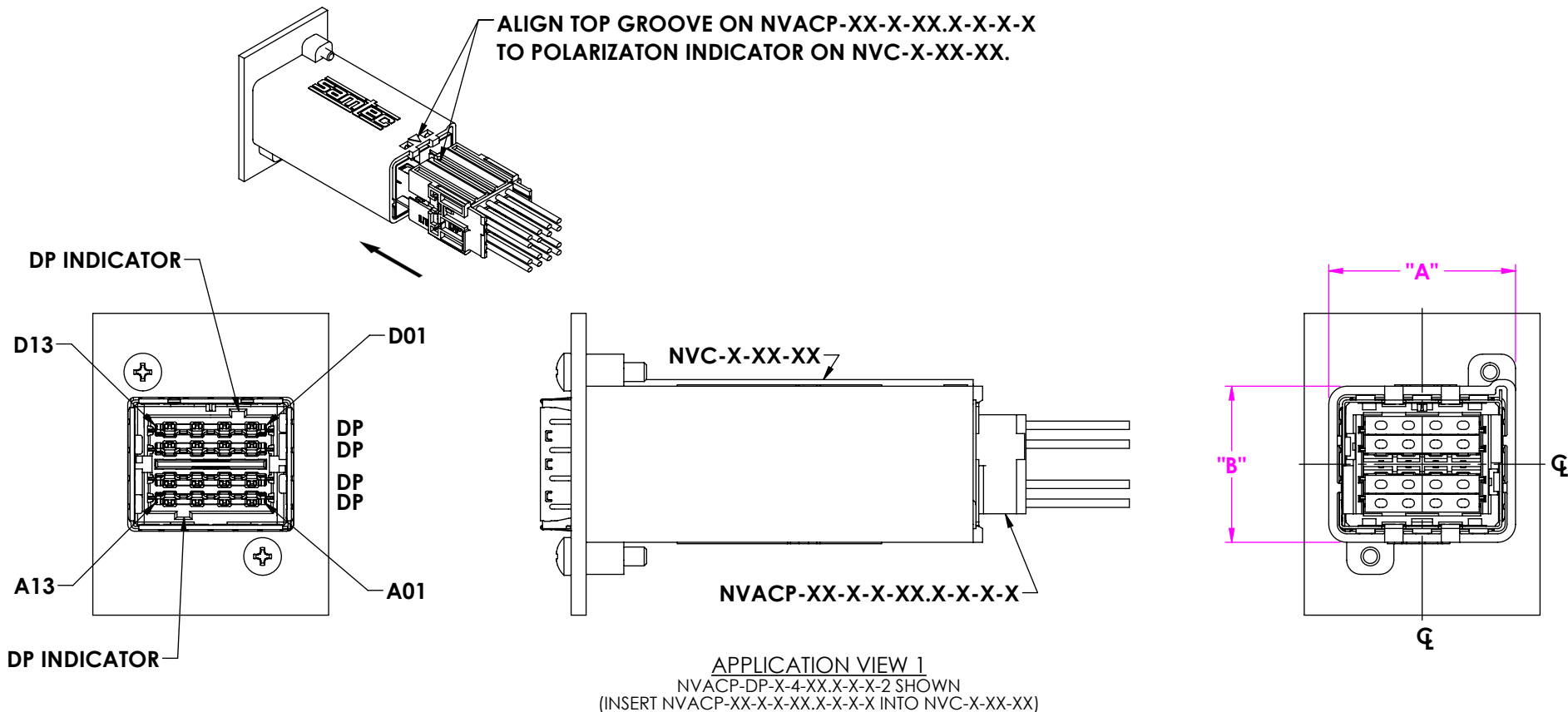

APPLICATION VIEW 2  
NVACP-DS-X-4-XX.X-X-X-2 SHOWN  
(SAME AS FIG 1, EXCEPT AS SHOWN)

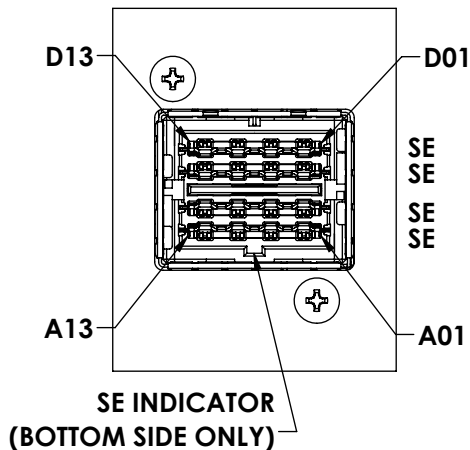

APPLICATION VIEW 3  
NVACP-SE-X-4-XX.X-X-X-2 SHOWN  
(SAME AS FIG 1, EXCEPT AS SHOWN)

TABLE 1	
No OF PORTS	"A"
-1	19.80 [0.780]
-2	19.80 [0.780]
-4	36.45 [1.435]

ROWS	"B"		
	No. OF PORTS		
	-1	-2	-4
-2	12.55 [0.494]	N/A	N/A
-4	16.55 [0.652]	N/A	N/A
-8	24.55 [0.967]	45.95 [1.809]	45.95 [1.809]

**PROPRIETARY NOTE**  
THIS DOCUMENT CONTAINS CONFIDENTIAL AND PROPRIETARY INFORMATION AND ALL DESIGN, MANUFACTURING, REPRODUCTION, USE, PATENT RIGHTS AND SALES RIGHTS ARE EXPRESSLY RESERVED BY SAMTEC, INC. THIS DOCUMENT SHALL NOT BE DISCLOSED, IN WHOLE OR PART, TO ANY UNAUTHORIZED PERSON OR ENTITY NOR REPRODUCED, TRANSFERRED OR INCORPORATED IN ANY OTHER PROJECT IN ANY MANNER WITHOUT THE EXPRESS WRITTEN CONSENT OF SAMTEC, INC.

DO NOT SCALE DRAWING  
SHEET SCALE: 2:1



520 PARK EAST BLVD, NEW ALBANY, IN 47150  
PHONE: 812-944-6733 FAX: 812-948-5047  
e-Mail info@SAMTEC.com code 55322

DESCRIPTION:  
NVACX MATED DOCUMENT

DWG. NO.  
NVACX MATED DOCUMENT

BY:KNOWL DEN 02/25/2022 SHEET 3 OF 4

DESIGNED & DIMENSIONED  
IN MILLIMETERS [INCHES]

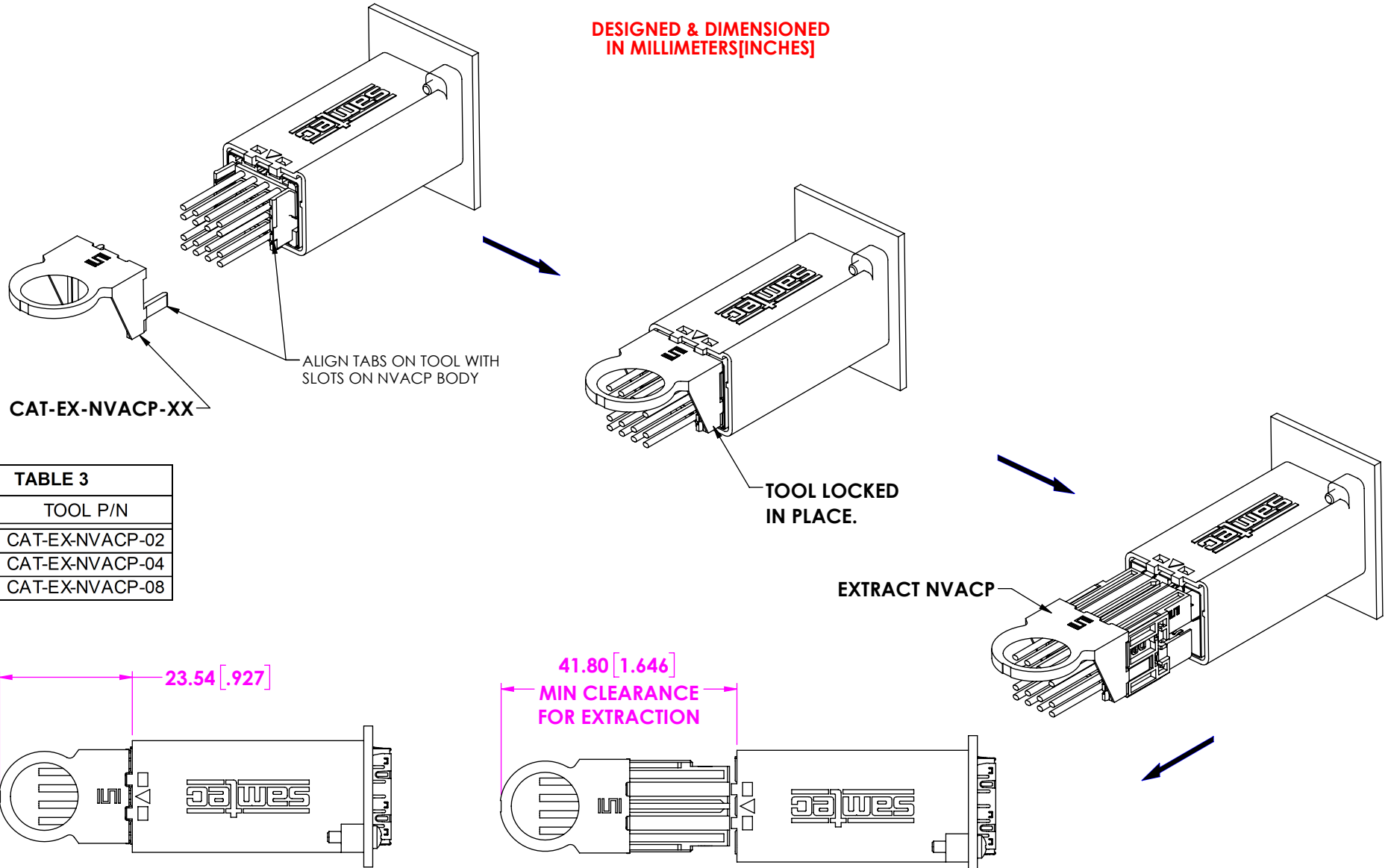

CAT-EX-NVACP-XX

ALIGN TABS ON TOOL WITH  
SLOTS ON NVACP BODY

TOOL LOCKED  
IN PLACE.

EXTRACT NVACP

**TABLE 3**

ROWS	TOOL P/N
-2	CAT-EX-NVACP-02
-4	CAT-EX-NVACP-04
-8	CAT-EX-NVACP-08

23.54 [0.927]

41.80 [1.646]

MIN CLEARANCE  
FOR EXTRACTION

NVACP EXTRACTION PROCESS  
NVACP-DP-X-4-XX.X-X-X-2 SHOWN  
(REMOVE NVACP-XX-X-X-XX.X-X-X-X FROM NVC-X-XX-XX)

**PROPRIETARY NOTE**  
\* THIS DOCUMENT CONTAINS CONFIDENTIAL AND PROPRIETARY INFORMATION AND ALL DESIGN, MANUFACTURING, REPRODUCTION, USE, PATENT RIGHTS AND SALES RIGHTS ARE EXPRESSLY RESERVED BY SAMTEC, INC. THIS DOCUMENT SHALL NOT BE DISCLOSED, IN WHOLE OR PART, TO ANY UNAUTHORIZED PERSON OR ENTITY NOR REPRODUCED, TRANSFERRED OR INCORPORATED IN ANY OTHER PROJECT IN ANY MANNER WITHOUT THE EXPRESS WRITTEN CONSENT OF SAMTEC, INC.



520 PARK EAST BLVD, NEW ALBANY, IN 47150  
PHONE: 812-944-6733 FAX: 812-948-5047  
e-Mail info@SAMTEC.com code 55322

DESCRIPTION:  
NVACX MATED DOCUMENT

DWG. NO.  
NVACX MATED DOCUMENT

BY: KNOWLDEN 02/25/2022 SHEET 4 OF 4